



SIREN8X

User Manual

Connections.....	1
Controls.....	2
Overview.....	2
Gain Staging.....	2
Manual Control.....	3
Volume Control.....	3
Phase.....	3
Mono Sum.....	3
LFO.....	4
Presets.....	5
LFO.....	6
MIDI Control.....	7
Controlling Volume.....	7
Controlling Phase and Mono Summing.....	7
Controlling the LFO.....	8
Waveform.....	8
Depth.....	8
Speed.....	8
Phase.....	8
MIDI Channel.....	9

The **Oscillator Devices SIREN8X** is a 4-channel MIDI-controlled stereo mixer. Its four fully analog stereo channels can be independently adjusted from -100 dB (mute) up to +10 dB of gain. An additional master volume control sets the overall output level. For all channels, including the master, the left and right channel levels can be adjusted independently. The **SIREN8X** is designed to handle both instrument- and line-level signals.

All channels feature independent phase inversion and mono summing. The latter allows the **SIREN8X** to function as a **mono mixer with up to eight channels**.

Each channel features two LFOs that can modulate the volume controls. All LFOs operate completely independently. Different waveforms (sine, square, and ramp in both directions) can either run freely with periods ranging from 100 ms to 1.2 s or be synchronized to MIDI clock.

Every parameter is MIDI controllable. There are also 32 presets available to save your settings.

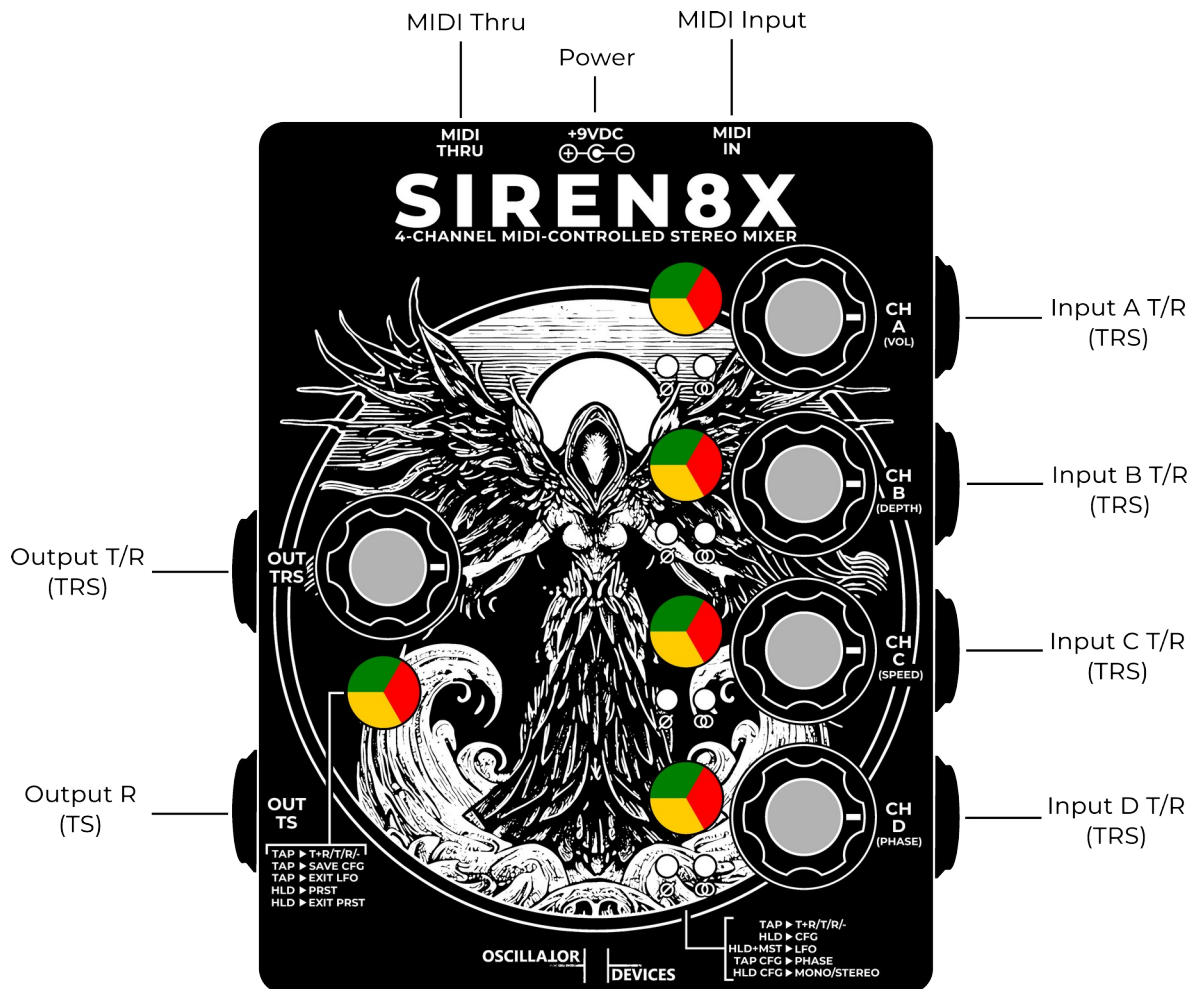

Connections

- **Input A/B/C/D T/R:** Four 1/4" stereo TRS jacks. Input impedance 1MΩ. Maximum input level 12 Vpp (+14.8 dBu).
- **Output:** Two 1/4" jacks. For use with a TRS stereo jack, use **OUT TRS**, for use with two mono jacks, use **OUT TS** for Tip and **OUT TS** for Ring. Output impedance 500Ω.
- **Power:** 9VDC only, Center Negative, Boss-style power supply. Min. 400mA.
- **MIDI In:** 3.5mm (1/8") MIDI Input according to MIDI Standard **MIDI TRS Type-A**.
- **MIDI Thru:** 3.5mm (1/8"), latency-free MIDI Thru according to MIDI Standard **MIDI TRS Type-A**

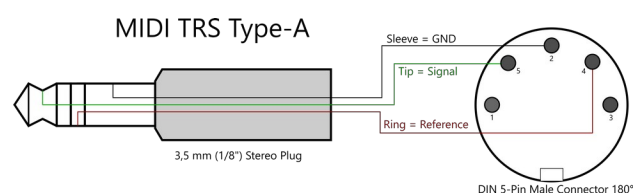

Controls

- **CH A/B/C/D:** This is the channel volume control. Please note, that unity gain is at three o'clock. These knobs can be used to control the volume of tip and ring independently (see chapter Manual Control) and can be used to set up the LFO (see chapter Error: Reference source not found).
- **OUT:** This is the master volume control. Unity gain is at three o'clock.
- **Channel Buttons:** Each channel features an illuminated button. When all buttons are lit solidly, press a button to select how the channel volume control operates:
 - **Orange:** Controls both tip and ring
 - **Green:** Controls only tip
 - **Red:** Controls only ring
 - **Off:** Disabled
- **Phase LED:** Each channel has two white LEDs. The left one is the Phase LED. When it lights up one or both channels have the phase flipped.
- **Mono Sum LED:** The white LED on the right is the mono sum LED. When it lights up tip and ring are summed and mixed with both tip and ring of the output.

Overview

An overview of a single channel is shown below. The volume controls are located directly after the input buffer. The optional mono sum either leaves the stereo signals unchanged or sums them and routes the resulting mono signal to both Tip and Ring. After optional phase inversion, the signals enter the main mixers, where they are summed with the signals from the other three identical channels. After passing through an additional master volume stage, the signals are routed to the output buffer.

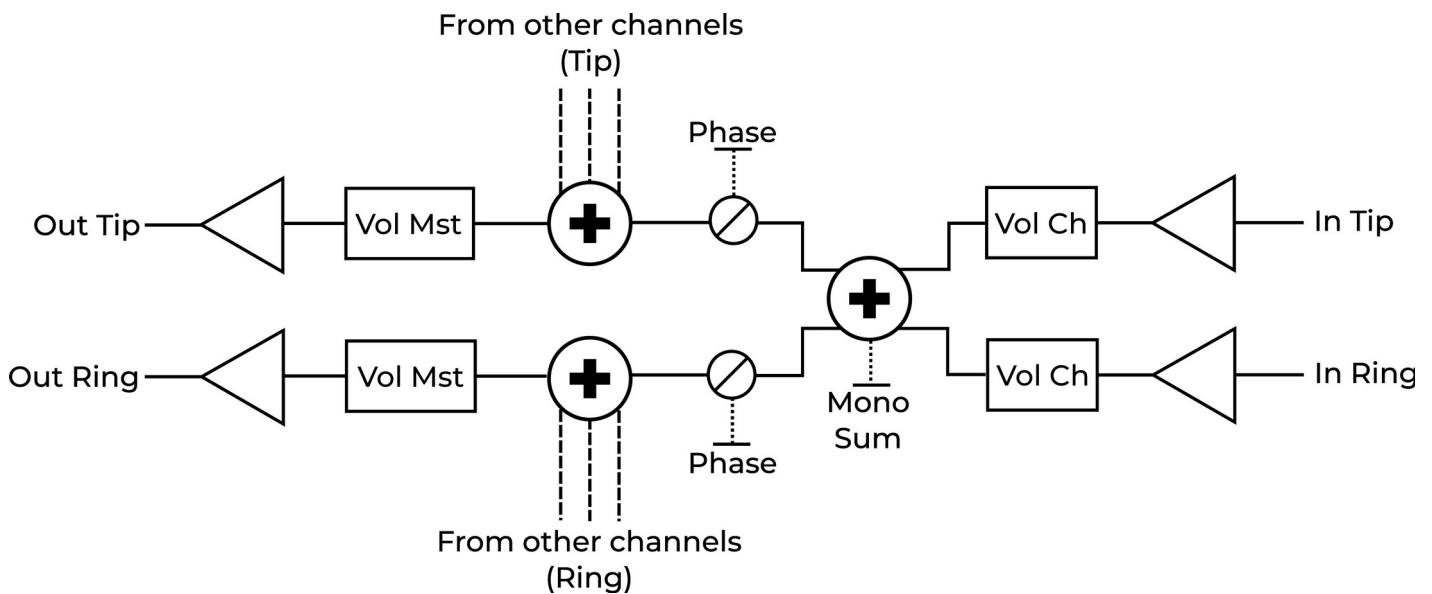

Gain Staging

A word on gain staging. It's good practice to run your effects rather hot and turn down the **SIREN8X** channels a bit, instead of just going unity gain. This improves noise performance of all involved devices and gives you more room to increase the volume later.

Manual Control

Volume Control

To manually change the volume, use the knobs. Set a knob to the three o'clock position to set the channel to unity gain. Turning the knob fully counter-clockwise mutes the channel, while turning it fully clockwise sets it to +10 dB gain. The button LEDs react subtly to volume changes. They become slightly dimmer when the volume is set below unity gain.

The buttons determine whether the volume adjustment affects the Tip signal, the Ring signal, or both. Pressing a button changes its color and therefore which signal the knob controls:

- **Orange:** The knob controls both Tip and Ring
- **Green:** The knob controls only Tip
- **Red:** The knob controls only Ring
- **Off:** The knob is disabled

When a channel is not controlled by the knob, its volume remains at the last set value. This value is also stored in non-volatile memory and will be restored the next time the device is powered on.

Phase

The **SIREN8X** can flip the phase of every channel and also flip Tip and Ring independently.

To change the phase setting of a channel, proceed as follows:

- Hold the channel button of the channel whose phase setting you want to change. The button starts blinking.
- Tap the button to cycle through the following phase settings:
 - **Orange blinking, Phase LED off:** No phase inversion.
 - **Orange blinking, Phase LED on:** Both Tip and Ring are phase inverted.
 - **Green blinking, Phase LED on:** Only Tip is phase inverted.
 - **Red blinking, Phase LED on:** Only Ring is phase inverted.
- When finished, press the Master button. All channel buttons will blink and the phase setting will be stored.

When stored using the button, the phase setting will persist even when the device is powered off.

Mono Sum

To use Tip and Ring as two independent mono channels, enable the Mono Sum function. This allows the **SIREN8X** to operate as a mono mixer with up to 8 channels or mix stereo and mono pedals.

To activate the mono sum function, proceed as follows:

- Hold the channel button of the channel for which you want to activate mono sum. The button starts blinking.
- Continue holding the button until the Mono Sum LED lights up. Mono sum is now enabled. Hold the button again until the LED turns off to disable mono sum.
- When finished, press the Master button. All channel buttons will blink and the mono sum setting will be stored.

When stored using the button, the mono sum setting will persist even when the device is powered off.

Please note that phase inversion is applied after the mono summing stage. Therefore, when using a channel with two mono signals from the same source, these signals must have the same phase relation, as signals with opposite phase may partially or completely cancel each other out.

LFO

The **SIREN8X** features two LFOs per channel, one for Tip and one for Ring. The LFOs can be configured independently, while maintaining a defined phase relationship, allowing them to be synchronized.

In addition to the waveform, each LFO provides four parameters:

- **Volume:** Determines the maximum level reached by the LFO.
- **Depth:** Determines how far the volume is reduced relative to the maximum level.
- **Speed:** The LFO can either be synchronized to MIDI clock or operate freely with a period ranging from 100 ms to 1.27 s.
- **Phase:** Determines the phase relationship of the LFO relative to the other LFOs. In other words, it defines the starting point within the waveform cycle.¹

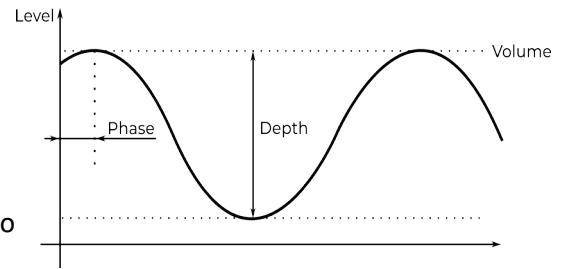

The LFOs can be configured using the knobs and buttons. To set up an LFO, proceed as follows:

- Hold the Master button and the channel button of the channel whose LFO you want to configure. The Master button and selected channel button will light up orange, while all other channel buttons turn off.
- Tap the channel button to cycle through the available waveforms. The channel LED provides a visual indication of the selected waveform:
 - Sine
 - Square
 - Ramp Forward
 - Ramp Backward
- Once a waveform has been selected, use the knobs to adjust the LFO parameters:
 - **CH A:** Controls the volume level.
 - **CH B:** Controls the depth.
 - **CH C:** Controls the speed. With the knob fully counter-clockwise, the LFO is synchronized to MIDI clock. Turning the knob clockwise enables free-running operation with periods ranging from 100 ms to 1.27 s.
 - **CH D:** Controls the phase relationship between the LFOs. Leave the knob fully counter-clockwise to keep all LFOs synchronized. Turning it clockwise shifts the selected LFO relative to the others. At the fully clockwise position, the phase shift is 180°, causing the LFOs to operate in opposite directions.
- When finished, tap the Master button to exit LFO setup mode.

LFO settings are not stored automatically. If the **SIREN8X** is powered off, the settings will be lost. Save them to a preset if you want to keep them.

To configure the LFO for only Tip or only Ring, first select Tip or Ring using the channel button before entering LFO setup.

To configure the LFOs of multiple channels simultaneously, hold the Master button and press the additional channel buttons to add them to the current LFO setup.

¹ In this context, *phase* refers to the position within the LFO cycle, not to the phase (polarity) of the audio signal.

Presets

The **SIREN8X** can store up to 32 presets. For each preset, individual channels can be excluded from being stored. For example, you may choose to exclude the master volume, allowing it to be adjusted to suit the room or amplifier while preserving the relative levels of all channels.

A preset stores the volume settings and LFO parameters. Phase inversion and mono sum settings are not included in presets.

To save a preset, proceed as follows:

- Hold the Master button until all buttons start flashing.
- You can now tap a channel button or the Master button to select which channels or channel parts will be included in the preset:
 - **Orange blinking:** Both Tip and Ring will be stored.
 - **Green blinking:** Only Tip will be stored.
 - **Red blinking:** Only Ring will be stored.
 - **Off:** This channel will not be stored in the preset.
- After configuring all channels, send the desired Program Change (PC) message (0–31). The preset will be stored and can later be recalled using the same PC message.

To cancel the procedure, simply hold the Master button again.

Apart from using PC messages for presets, CC messages can be used to recall settings of individual channels only:

CC	#	Function
14	0-31	Recall preset of channel A only
15	0-31	Recall preset of channel B only
16	0-31	Recall preset of channel C only
17	0-31	Recall preset of channel D only
18	0-31	Recall preset of Master channel only

MIDI Control

Controlling Volume

There are several CC commands to change the volume of the channels. The following commands set the volume of the channels to an absolute value from 0 (Mute) to 127 (+10dB).

CC						Function
Ch A	Ch B	Ch C	Ch D	Master	#	
20	40	60	80	100	0-127	Volume of Tip+Ring of the respective channel. 0 = Mute, 101 = Unity Gain, 127 = +10dB Overrides the setting of the knob.
21	41	61	81	101	0-127	Volume of Tip of the respective channel. 0 = Mute, 101 = Unity Gain, 127 = +10dB Overrides the setting of the knob.
22	42	62	82	102	0-127	Volume of Ring respective channel. 0 = Mute, 101 = Unity Gain, 127 = +10dB Overrides the setting of the knob.
23	43	63	83	103	0-127	Volume of Tip or Ring selected by the button of respective channel. 0 = Mute, 101 = Unity Gain, 127 = +10dB. Overrides the setting of the knob.
24	44	64	84	104	0-127	Panning of the respective channel. 0 = Tip Mute and Ring Unity Gain, 127 = Tip Unity Gain and Ring Mute. Overrides the setting of the knob.

The following commands set the volume of the channels to a value relative to the setting of the knob.

CC						Function
Ch A	Ch B	Ch C	Ch D	Master	#	
25	45	65	85	105	0-127	Volume of Tip+Ring of the respective channel relative to the knob setting . For example, a value of 127 for this CC corresponds to the volume level currently set by the knob. If the knob is set to the 3 o'clock position, a value of 127 for this CC results in approx. unity gain.
26	46	66	86	106	0-127	Volume of Tip of the respective channel relative to the knob setting . For example, a value of 127 for this CC corresponds to the volume level currently set by the knob. If the knob is set to the 3 o'clock position, a value of 127 for this CC results in approx. unity gain.
27	47	67	87	107	0-127	Volume of Ring of the respective channel relative to the knob setting . For example, a value of 127 for this CC corresponds to the volume level currently set by the knob. If the knob is set to the 3 o'clock position, a value of 127 for this CC results in approx. unity gain.
28	48	68	88	108	0-127	Volume of Tip or Ring selected by the button of respective channel relative to the knob setting . For example, a value of 127 for this CC corresponds to the volume level currently set by the knob. If the knob is set to the 3 o'clock position, a value of 127 for this CC results in approx. unity gain.
29	49	69	89	109	0-127	Panning of the respective channel relative to the knob setting . 0 = Tip Mute and Ring at knob setting, 127 = Tip at knob setting and Ring Mute.

Controlling Phase and Mono Summing

The following commands set phase and mono summing. These commands are temporary. To set phase and mono summing persistently use the buttons.

CC						Function
Ch A	Ch B	Ch C	Ch D	#		
30	50	70	90	0-3	0 = Phase Normal 1 = Phase flipped on both Tip and Ring 2 = Phase flipped only on Tip 3 = Phase flipped only on Ring	
31	51	71	91	0-1	0 = No mono summing (Stereo) 1 = Mono summing (Mono)	

Controlling the LFO

The volume control can be driven by two LFOs (low-frequency oscillators) per channel, either free-running from 100ms to 1.27s time, or synced to MIDI clock with various time divisions. The LFO can run in different waveforms:

- **Sine:** A normal, smooth sine wave
- **Rectangular:** Perfect for a slicer or stutter effect
- **Ramp:** Forward or backward, for repeated swells, for example.

Like explained in section Error: Reference source not found, every LFO waveform is controlled by four parameters: Volume, Depth, Speed and Phase. Volume is still controlled by the volume control commands in section Controlling Volume.

Waveform

CC									Function
Ch A		Ch B		Ch C		Ch D		#	
Tip	Ring	Tip	Ring	Tip	Ring	Tip	Ring		
32	36	52	56	72	76	92	96	0-4	0 = LFO off 1 = Sine Wave 2 = Square Wave 3 = Ramp Forward (Rising) 4 = Ramp Backward (Falling)

Depth

CC									Function
Ch A		Ch B		Ch C		Ch D		#	
Tip	Ring	Tip	Ring	Tip	Ring	Tip	Ring		
33	37	53	57	73	77	93	97	0-127	0 = LFO off 127 = Full Depth from set Volume to mute

Speed

CC									Function
Ch A		Ch B		Ch C		Ch D		#	
Tip	Ring	Tip	Ring	Tip	Ring	Tip	Ring		
34	38	54	58	74	78	94	98	0	LFO off
								1	Synced to MIDI Clock 1/4 note
								2	Synced to MIDI Clock 1/8 note
								3	Synced to MIDI Clock triplets
								4	Synced to MIDI Clock 1/16 note
								5	Synced to MIDI Clock dotted 1/8 note
								6	Synced to MIDI Clock half note
								7	Synced to MIDI Clock whole note
								8	Synced to MIDI Clock 1/32 note
								10-127	Free-running from 100ms (=10) to 1.27s (=127)

Phase

Every digit introduces a phase shift of 22.5° (360°/16).

CC									Function
Ch A		Ch B		Ch C		Ch D		#	
Tip	Ring	Tip	Ring	Tip	Ring	Tip	Ring		
35	39	55	59	75	79	95	99	0-15	0 = No phase shift 8 = 180° phase shift (like fully clockwise of the knob) 15 = 337.5° phase shift

MIDI Channel

The **SIREN8X** ships in omni mode (i.e. it responds to any channel).

To change the MIDI channel, proceed as follows:

1. Disconnect the device from the power supply
2. Press and hold the **Master** button and restore the power while the button is pressed.
3. Once the boot process is complete, all LEDs and buttons will begin flashing. Press the Master button the number of times corresponding to the desired MIDI channel (e.g. twice for channel 2). The **SIREN8X** confirms the selected channel by emitting a series of short flashes corresponding to the channel number.
4. Once the desired channel has been selected, press and hold the Master button. The LEDs will stop flashing, followed by one final flash. The MIDI channel is now stored.
5. Disconnect the supply voltage. The next time the **SIREN8X** is powered on, it will respond to the selected MIDI channel.

To put the SIREN in omni mode skip step 3.